

Small footprint, general purpose, top-entry constant current accelerometer with an isolated AC output. Made from robust stainless steel throughout for long term vibration analysis in harsh environments. Specially adapted for use on light weight, high speed machinery. Sealed to IP67 and includes integral stainless overbraided ETFE cable available with a wide range of mountings including quick release, swivel base. Ultra-slim 15mm body.

MTN/1130

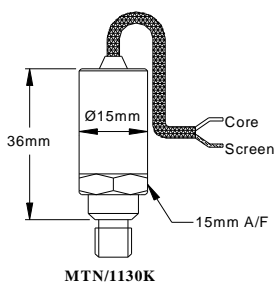

Dimensions

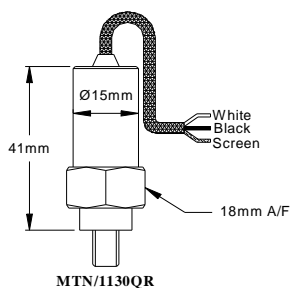
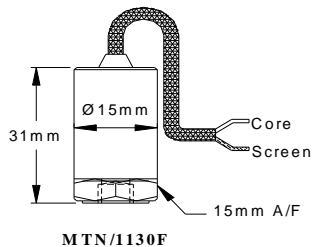

Applications

- General Industry
- Machine Tools
- Paper machinery
- Pumps, Fans, etc
- Air Handling Units
- Machine Tools

Technical

Standard Sensitivity	100 mV/g +/-10% nominal at 80 Hz
Frequency Response	2Hz to 15kHz +/-5%, (-3dB at 0.8Hz)
Mounted Base Resonance	22 kHz (nominal)
Isolation	Base Isolated
Temperature Sensitivity	0.08 %/°C
Transverse Sensitivity	Less than 5%
Electrical Noise	0.1 mg max
Current Range	0.5 mA to 8 mA
Temperature Range	-55 to 140°C
Bias voltage	12 Volts DC (nominal)
Case Material	Stainless Steel
Cable	Integral Stainless Steel O/B ETFE
Standard Cable Length	5 metres
Maximum Cable Length	100 metres
Mounting Torque	8Nm (for M8 and M6, 6Nm (for 10-32 UNF)
Weight	30 gms (nominal)
Sealing	IP67

Mounting Adaptors and Studs

1130 Male Studs



Part #	From	To
MS028	10-32 UNF Male	M8 Male
MS039	10-32 UNF Male	1/4"-28 UNF Male
MS065	10-32 UNF Male	M6 Male

Grub screws

Part #	From
MS024	10-32 UNF Male

ORDER CODE PART No	MOUNTING
MTN/1130F	10-32 UNF Female
MTN/1130K	M8 Male conical
MTN/1130QR	M6 Male Swivel

System Connection Details

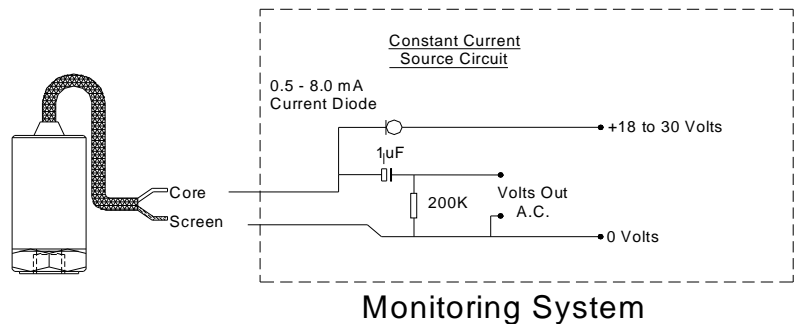

Note: Connection details for the MTN/1130QR with twin core cable vary from the above such that the core is replaced by white; screen replaced by black & the screen is then not connected.