

General purpose, side-entry, constant current accelerometer with isolated AC output. Made from robust stainless steel throughout for long term vibration analysis in harsh environments. Sealed to IP67 and includes integral stainless steel overbraided ETFE cable and ¼"-28 UNF, M6 or M8 mounting bolt.

MTN/1100SC



Applications

- General or heavy industry
- Data collection
- Paper machinery
- Pumps, fans etc
- Air handling units
- Machine tools

Technical

Standard sensitivity	100mV/g ±10% nominal @ 80Hz
----------------------	-----------------------------

Frequency response	2Hz to 10kHz ±5% (-3dB @ 0.8Hz)
--------------------	---------------------------------

Mounted base resonance	18kHz (nominal)
------------------------	-----------------

Isolation	Base isolated
-----------	---------------

Dynamic range	±80g
---------------	------

Transverse sensitivity	Less than 5%
------------------------	--------------

Electrical noise	0.1mg max
------------------	-----------

Current range	0.5 to 8mA
---------------	------------

Temperature range	-55 to 140°C
-------------------	--------------

Bias voltage	12V DC (nominal)
--------------	------------------

Case material	Stainless steel
---------------	-----------------

Cable	Integral stainless steel overbraided ETFE
-------	-------------------------------------------

Standard cable length	5m
-----------------------	----

Maximum cable length	100m
----------------------	------

Mounting torque	8Nm
-----------------	-----

Weight	170g (nominal)
--------	----------------

Sealing	IP67
---------	------

Dimensions

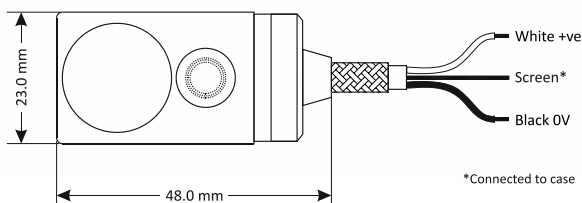
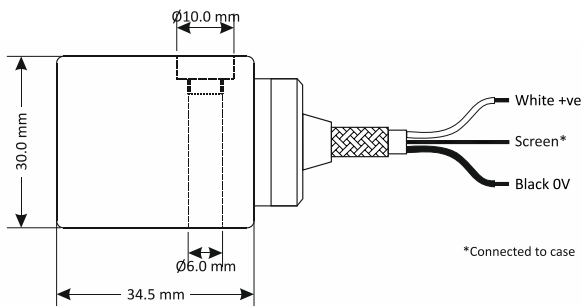

Options

- Mounting bolts (see below)

Part #	Mounting	xx = Optional sensitivity ($\pm 10\%$)
MTN/1100SC-xx	1/4"-28 UNF x 33mm	10
MTN/1100SCM6-xx	M6 x 35mm	25
MTN/1100SCM8-xx	M8 x 28mm	50

System connection

